

# Recent News

## Ultra High Efficiency ViVa<sup>®</sup> 3mm Piezo Actuator

### Technical Press Release

Viking AT announces its ViVa series Solid State Electromechanical Actuators. These revolutionary devices utilize efficient piezoceramics driving a uniquely engineered active frame which amplifies the piezo displacement by a factor of 50, 100 or 200 times to produce an ultra-high efficient and accurate voltage controlled mechanical actuator.

Today's power requirements are simple; ***less power and better performance!***

### Power Consumption:

The ViVa actuators achieve maximum efficiency by effectively utilizing the piezoelectric effect. Piezoceramics are voltage devices, not current devices. This means they function with a static voltage applied and do not rely on current flow to function. This also means much lower power consumption, typically up to 98% less than a solenoid. Due to low current draw, the piezoceramic has little to no heat emission.

### Input Proportional Control:

ViVa actuators operate with DC voltage applied as either static or complex waveform.

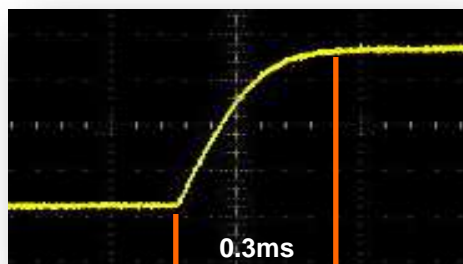

Output displacement is accurate and proportional to the input voltage. Operating in its linear region, half the voltage = half the displacement. Holding a proportional static position is most efficient of all with almost no current draw. All this with a simple DC voltage applied and no need for complicated PWM drivers with not so accurate results. As shown below, the solenoid consumes 200x more power than the ViVa to hold the valve open.

Commercial valve with original solenoid (green & yellow) & same valve with ViVa (pink)

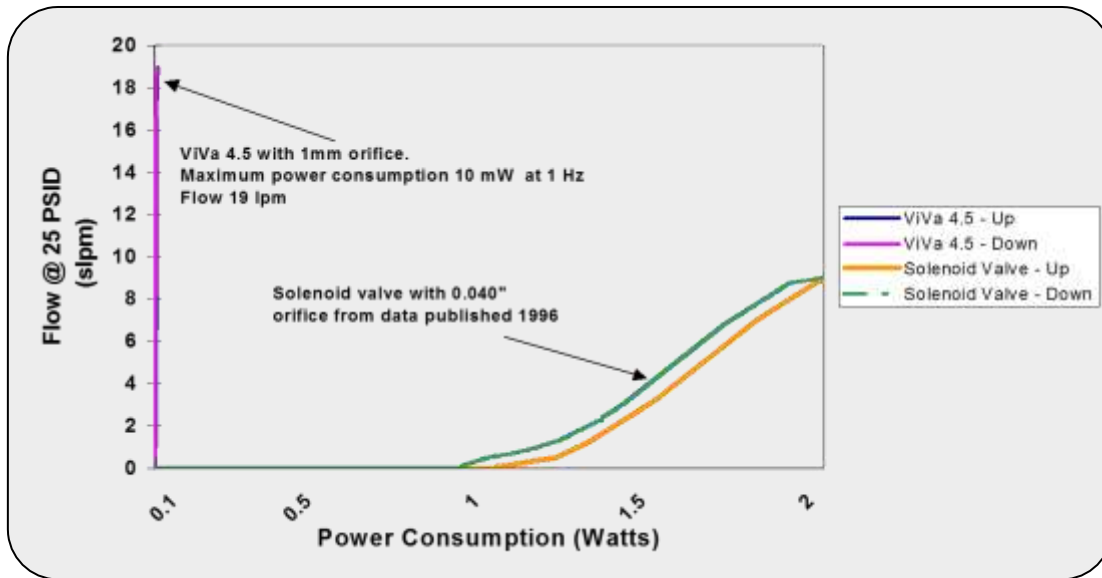

**Mechanical Characteristics & Performance:**

The ViVa actuator’s uniquely engineered active frame inherently contains no frictional parts. Active members operate only within the infinite life region of the material which allows for more than a billion cycles and beyond. No frictional parts mean no wear residue to contaminate ultra clean environments.

Ultra quick response time and accurate reciprocating action allow for efficient operation even up to 1,000 Hz. Symmetrical force output means equal force while pushing or pulling, no need for return springs or force. Viva actuators can be configured as a single stage toggle arm output or two-stage linear output producing mechanical displacement from .010” to .250” and forces ranging from grams to 45lbs.

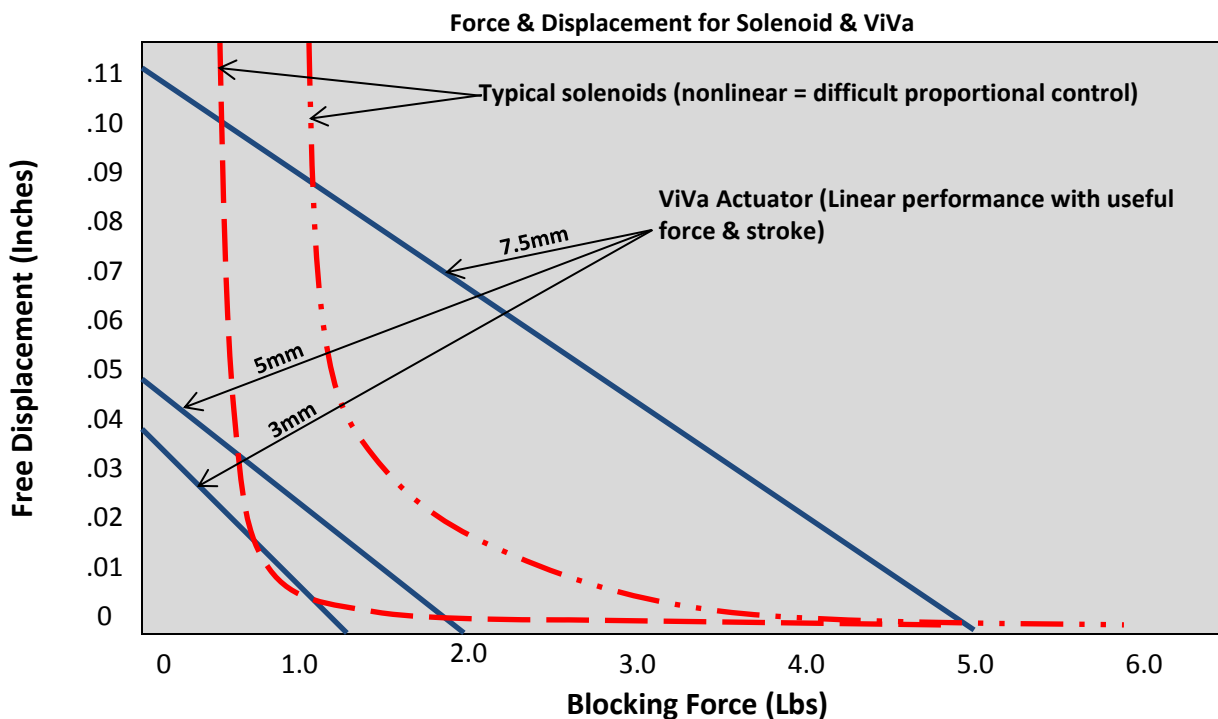

## Applications & Other Benefits:

Utmost reliability and superior resistance to vibration make the ViVa stand out for clean, precise, long lasting reliable service in almost any environment and applications such as; Valves, Grippers, Door Locks, Linear Actuators and Replacement of solenoids.

Other benefits include;

- Low magnetic signature
- Low noise operation
- Extreme life cycles
- Multi configurable
- Integrate-able positional feedback
- Integrate-able force & pressure sensing

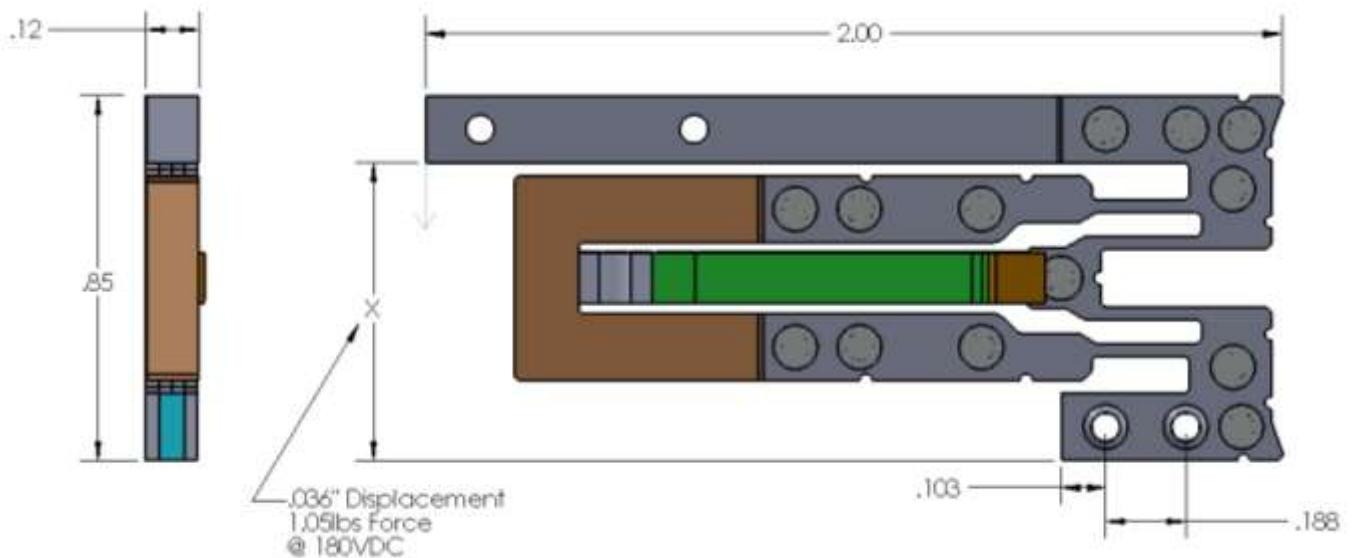

ViVa 3mm Actuator configured as single stage with single toggle arm.

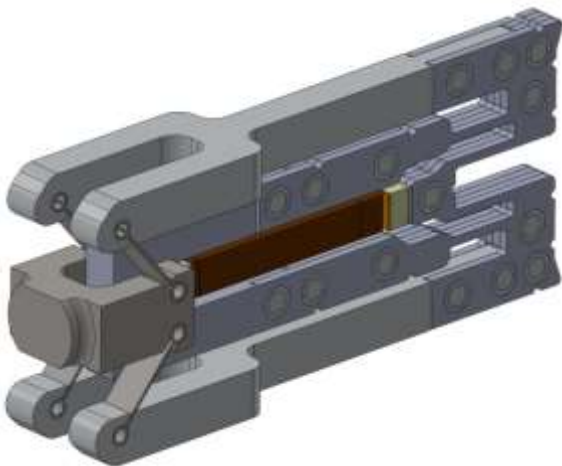

ViVa 3mm Actuator configured as 2-stage linear with two toggle arm 1<sup>st</sup> stage.



ViVa 3mm Actuator configured as single stage with two toggle arms.